

Sl. No.

74186

A-DMHH-N-FUB

**ELECTRONICS AND  
TELECOMMUNICATION ENGINEERING**

**Paper—II**

( Conventional )

Time Allowed : Three Hours

Maximum Marks : 200

**INSTRUCTIONS**

*Please read each of the following instructions carefully before attempting questions.*

Candidates should attempt FIVE questions in all.

Question No. 1 is compulsory.

Out of the remaining SIX questions, attempt any FOUR questions.

All questions carry equal marks. The number of marks carried by a part of a question is indicated against it.

Answers must be written in ENGLISH only.

Assume suitable data, if necessary, and indicate the same clearly.

Unless otherwise mentioned, symbols and notations have their usual standard meanings.

Neat sketches may be drawn, wherever required.

All parts and sub-parts of a question are to be attempted together in the answer-book.

Attempts of questions shall be counted in chronological order. Unless struck off, attempt of a question shall be counted even if attempted partly.

Any page or portion of the page left blank in the answer-book must be clearly struck off.

One linear graph sheet is attached to this question paper. This should be carefully detached for use by the candidate and securely attached to the answer-book.

1. Answer all of the following :

(a) A *p-n-p* transistor has  $V_{EB} = 0.8$  V at a collector current of 1 A. What do you expect  $V_{EB}$  to become at  $i_C = 10$  mA and at  $i_C = 5$  A? 5

(b) For a particular IC fabrication, the quantity  $\frac{1}{2}\mu_n C_{ox} = 10 \mu\text{A}/\text{V}^2$  and  $V_t = 1$  V.

In an application in which

$$V_{GS} = V_{DS} = V_{\text{supply}} = 5 \text{ V}$$

a drain current of 0.8 mA is required of a device of minimum length 2  $\mu\text{m}$ . What value of channel width must the design use? 5

(c) Implement the logic expression

$$Y = AB + CD + EF$$

using CMOS transistors. 5

(d) If the forward path transfer function of a non-unity feedback system is

$$G(s) = \frac{K_1(1 + sT_1)}{s(1 + sT_2)}$$

and the transfer function of the feedback element is

$$H(s) = \frac{K_2(1 + sT_3)}{1 + sT_4}$$

find the steady-state error for unit-step and unit-ramp input signals. 5

- (e) A 12-cavity cylindrical magnetron of 5 mm anode radius, 3 mm cathode radius, operates at 2450 MHz, with a flux density of  $0.18 \text{ Wb/m}^2$  and anode voltage of  $V_0 = 3500 \text{ V}$ . Find the cut-off voltage for the given flux density and cut-off flux density for the given  $V_0$ . 5

- (f) Find the carrier and modulating frequencies, the modulation index and the maximum deviation of the FM wave represented by the voltage equation

$$v = 12 \sin(6 \times 10^8 t + 5 \sin 1250 t)$$

What power will this FM wave dissipate in a  $10 \Omega$  resistor? 5

- (g) Give details of all the components of the 'Bus Interface Unit (BIU)' in the 8086 microprocessor. 5

- (h) What is a pointer in C? How is it initiated? Give an example. 5

2. (a) Consider the large signal BJT models shown in Figs. 2.a<sub>1</sub> and 2.a<sub>2</sub>. What are the relative sizes of the diodes  $D_E$  and  $D_b$  for transistors for which  $\beta = 10$ ? 10

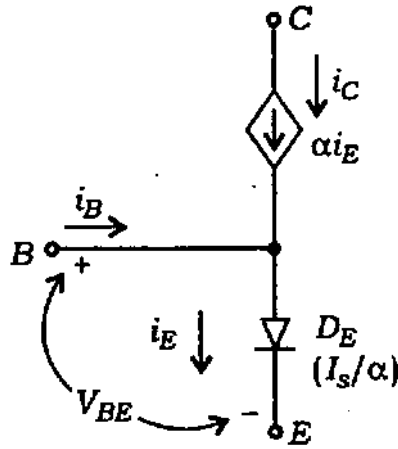

Fig. 2.a<sub>1</sub>

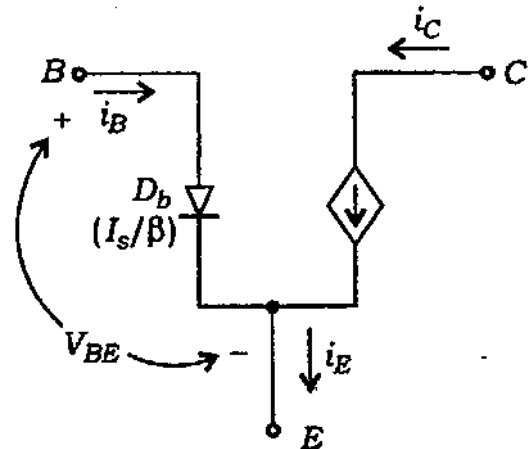

Fig. 2.a<sub>2</sub>

- (b) For the circuit of Fig. 2.b<sub>2</sub>, an ideal diode is used. Sketch the output for the input shown in Fig. 2.b<sub>1</sub>. Label the most positive and negative output levels. Assume  $CR \gg T$ . 10

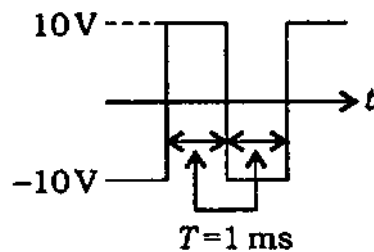

Fig. 2.b<sub>1</sub>

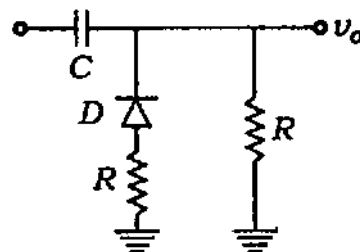

Fig. 2.b<sub>2</sub>

- (c) Consider the circuit shown in Fig. 2.c. Suppose the operational amplifier is  $\mu\text{A}741$  op-amp. Model the operational amplifier as an ideal op-amp. Determine how the output voltage,  $v_o$ , is related to the input voltage,  $v_s$ . 10

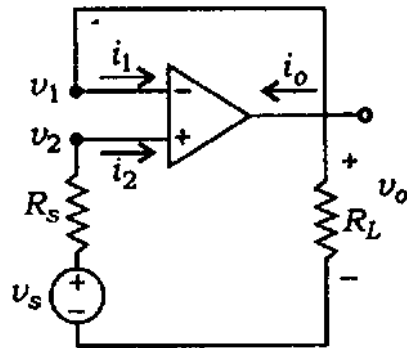

Fig. 2.c

For  $\mu\text{A}741$ ,  
 $v_{\text{sat}} = 14 \text{ V}$ ,  $i_{\text{sat}} = 2 \text{ mA}$   
 SR = Slew rate limit  
 $= 5 \times 10^5 \frac{\text{V}}{\text{s}}$   
 Supply voltages  $+15 \text{ V}$   
 and  $-15 \text{ V}$

- (d) Analyze the circuit of Fig. 2.d to determine the drain current and the drain voltage. Assume that the depletion type MOSFET has  $V_t = -1.0 \text{ V}$ ,  $k = 0.5 \text{ mA/V}^2$  and  $\lambda = 0$ . 10

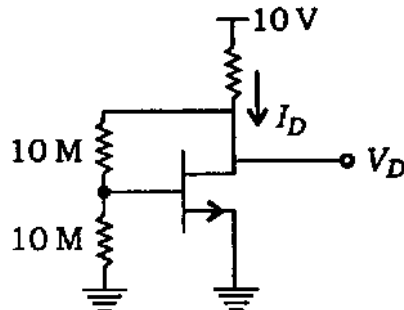

Fig. 2.d

3. (a) Draw a gate level diagram of a BCD adder and explain its operation with an example. 10
- (b) Design a two-input, two-output sequence detector which produces an output '1' every time the sequence 0101 is detected and an output '0' otherwise. 10
- (c) Design the circuit of an XNOR using AOI gate and explain how it can be used as a 1-bit comparator. Use the basic gates. 10
- (d) Realize the following gates using CMOS static gates. Explain the operations with the truth table : 10
- (i)  $Y = \overline{(A + B)}$
- (ii)  $Y = A \oplus B$

4. (a) The open-loop transfer function of a unity feedback system is given by

$$G(s) = \frac{K}{(s+2)(s+4)(s^2+6s+25)}$$

Find the values of  $K$  which will cause sustained oscillations in the closed-loop system. What are the corresponding oscillation frequencies? 10

- (b) A unity feedback system has the open-loop transfer function

$$G(s) = \frac{K}{s(s+p)}$$

Determine the values of  $K$  and  $p$  so that the settling time and peak overshoot will be 4 seconds and 10% respectively. Take  $\pm 2\%$  of the steady-state value definition for settling time.

10

- (c) The open-loop transfer function of a unity feedback system is given by

$$G(s) = \frac{K}{s(sT+1)}$$

- (i) By what factor the amplifier gain  $K$  should be multiplied so that the damping ratio is increased from 0.2 to 0.8?
- (ii) By what factor the time constant  $T$  should be multiplied so that the damping ratio is reduced from 0.6 to 0.3?

Find the range of  $K$  for which the system whose characteristic equation is given below is stable :

$$s^3 + (K + 0.5)s^2 + 4Ks + 50 = 0 \quad 10$$

- (d) In the feedback system shown in Fig. 4.d

$$G(s) = \frac{K}{s\tau_1(1+s\tau_1)(1+s\tau_2)}$$

- . Using the Hurwitz-Routh method, determine the necessary conditions for the system to be stable. 10

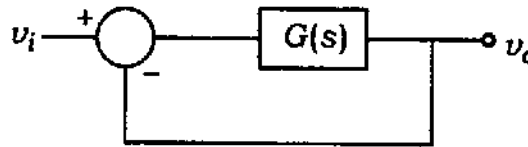

Fig. 4.d

5. (a) Let the modulating signal  $m(t)$  be a sinusoidal of amplitude  $A$  and frequency  $f_0$  in a delta modulator.

(i) If the step size  $S$  is larger than  $2A$ , show that  $\hat{m}(t)$ , the approximation to the input signal  $m(t)$ , is no longer valid.

(ii) In order to avoid slope overload in DM, prove that the  $A_{\max} = \frac{Sf_s}{2\pi f_0}$ , where  $f_s$  is the sampling frequency.

(iii) Show that in order to avoid both step size limiting and slope overload, the condition  $f_s > 3f_0$  must be satisfied.

15



(b) An optical fiber system employs an LED transmitter which launches an average of  $300 \mu\text{W}$  of optical power at a wavelength of  $0.8 \mu\text{m}$  into the optical cable. The cable has an overall attenuation of  $4 \text{ dB/km}$ . The APD receiver requires 1200 incident photons in order to register a binary '1' with a BER of  $10^{-10}$ . Determine the maximum distance (without repeaters) provided by the system when the transmission rate is 1 Mbps. 15

(c) A continuous random variable  $X$  is constrained to a peak magnitude  $M$ . Show that—

(i) the differential entropy of  $X$  is maximum when it is uniformly distributed;

(ii) the maximum differential entropy of  $X$  is  $\log_2 2M$ . 10

6. (a) Determine the propagating modes in a rectangular waveguide of  $1.0 \text{ cm} \times 2.3 \text{ cm}$ , at  $11.0 \text{ GHz}$ , if the guide is (i) air-filled and (ii) filled with dielectric of refractive index 1.5. Identify the frequency range of propagation for the dominant mode, and calculate the propagation constant at  $6.0 \text{ GHz}$  for that mode in both the cases. 15

- (b) For the 2-element array of short dipoles shown in Fig. 6.b, find the normalized resultant field and sketch the patterns in  $XZ$ -plane using pattern multiplication. Given that  $d = \lambda/4$ , and inter-element phase difference  $\alpha = -\pi/2$ . Assume uniform excitation amplitudes. 15

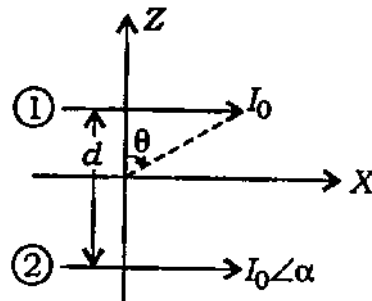

Fig. 6.b

- (c) For a junction of two lossless transmission lines of characteristic impedances  $Z_1$  and  $Z_2$ , find the scattering matrix with and without using normalized voltages. 10
7. (a) Write an 8085 ALP to multiply respective bytes of two arrays each 16 bytes long stored in memory sequentially from 2000H and 3000H respectively. The resulting array should be from 4000H. Write your program from 5000H and the multiplication subroutine from 6000H. Assume positive numbers and each multiplication is less than  $255_{10}$ . 20

- (b) If CS = 0000H, DS = 1000H, ES = SS = 2000H, BP = BX = SI = DI = A000H and SP = 0000H, then explain and indicate the locations from which data required for the following instructions would be fetched : 10

```
MOVSB  
JMP [BP+10H]  
IN AX, DX  
IDIV [1234]  
CALL FARPTR [2000H]
```

- (c) Write a C program segment to generate first  $n$  ( $n \geq 3$ ) Fibonacci numbers. Use an iterative method. Explain the flowchart also. 10

\*\*\*